

SKID LIFT™

LV & LVE SKID LIFTS

Bishamon®

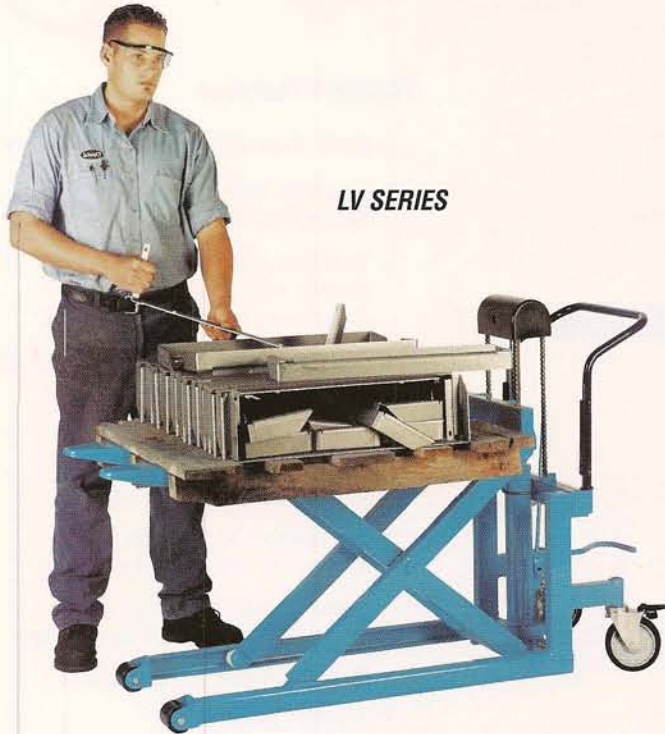

LV SERIES



Accessory tables mount on top of the forks.



Forks lower to 3.3 in. for optimal clearance under skids.



Locking foot brake is standard.

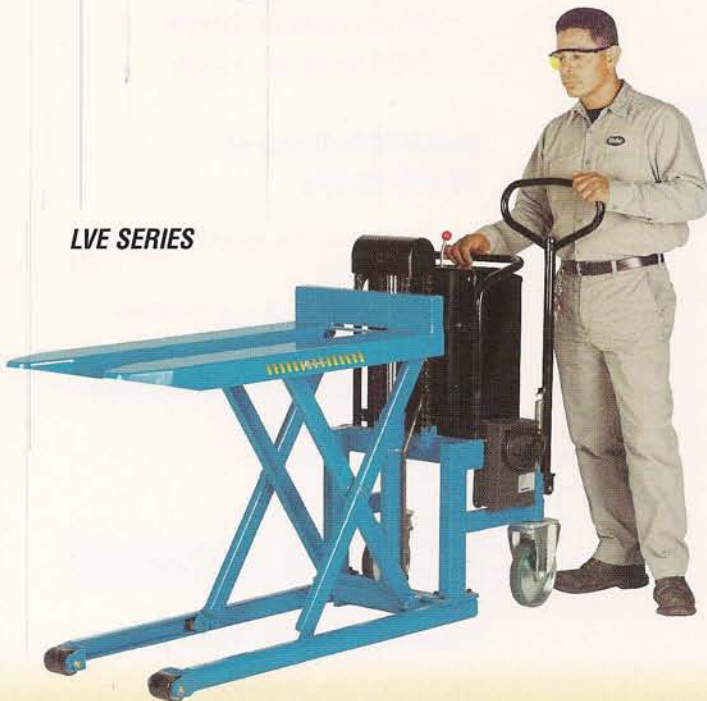

LVE SERIES



Twin heavy duty lifting chains provide a 2:1 lifting ratio for shorter lift stroke and reduced cylinder wear.

Bishamon skid lifts are rugged high-rise, fork style lifts that provide improved ergonomics and a functional ease of access for your workforce. By raising the top of the load to a convenient working height and providing easy mobility, skid lifts improve material handling productivity, increase efficiency and reduce potential worker injury - adding profit to your bottom line.

LV series skid lifts are available in eight models that include both wide and narrow fork widths and capacities to 2,200 lbs. Manual models have an integrated foot pump while a 12-volt DC power unit provides the lifting power on electric models. All models have variable raise and lower controls that allow the forks to be accurately positioned anywhere between the lower and upper travel limits. These versatile lifts have a dual functionality - not only do they lift and lower skids (open bottom, euro style pallets), the mobility feature allows the skids to be moved in and out of the work cell.

LV skid lifts are simple to operate, rugged and versatile and like all Bishamon products they are better by design. Twin heavy-duty lifting chains and a complete structural frame with captured rollers ensures superior stability and a lift that is capable of meeting today's demanding applications. Not only are they built SMART, they are built BISHAMON TOUGH - for years of trouble free operation.

Bishamon

Bishamon Industries Corporation

5651 East Francis Street
Ontario, California 91761-3601

(909) 390-0055 • (800) 358-8833
Fax (909) 390-0060

www.bishamon.com

Warranty - Bishamon Industries Corp. ("Bishamon") warrants its products to be free from defects in material and workmanship for a period of one (1) year from the date of initial shipment. This warranty shall not apply to any misuse, mishandling, accident, shipping, alteration, or unauthorized repair of any Bishamon product or part. For complete details of warranty, please contact Bishamon at 800-358-8833.

SKID LIFT™

LV & LVE SKID LIFTS

Working Harder To
Make Your Life Easier

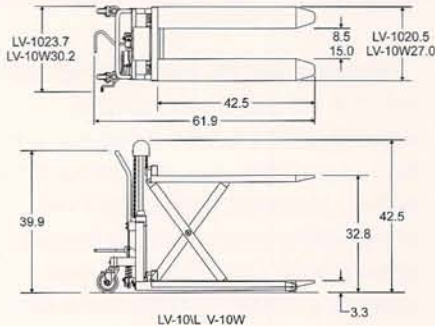

LV-10 / LV-10W

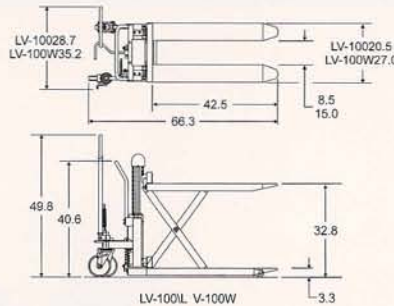

LV-100 / LV-100W

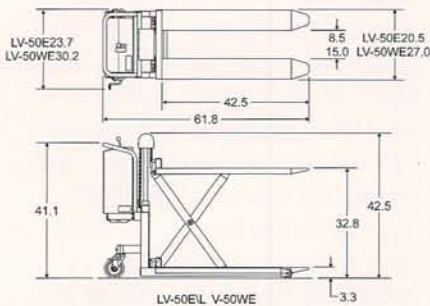

LV-50E / LV-50WE

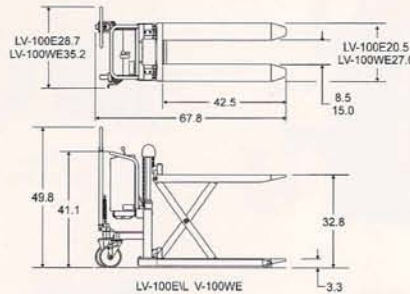

LV-100E / LV-100WE

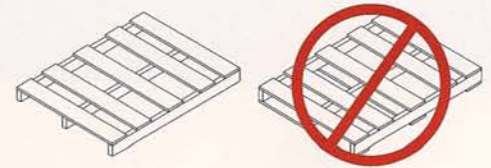

Standard Features

- Easily accessible hand and foot controls
- Precision, heavy duty steel construction throughout
- Twin heavy duty chains with 2-to-1 cylinder lifting ratio for improved cylinder wear and performance
- Lower captured roller channel provides increased and superior stability
- 2,200 lbs. capacity models have an offset 180 degree rotating steering handle
- Polyurethane wheels with roller bearings for better maneuverability
- Superior hydraulic system proven on a range of Bishamon lift products
- Caster with locking foot brake
- Travel of 29.5 inches
- 3.3 inch lowered fork height
- Quality baked enamel finish

Standard Features of DC LVE Models

- Easily accessible up/down lever hand control
- Built-in battery charger with timer
- Heavy-duty group 24 deep cycle battery
- Easy access battery disconnect plug
- Fused motor circuit

Selector Table for LV Series

Model	Travel (inches)	Capacity (lbs.)	Overall Fork Dimensions (in.)		Fork Height (in.)		Strokes or Lift Speed	Shipping Weight (lbs.)
			Width (OD)	Length	Lowered	Raised		
<i>Manual Foot Pedal Pump Operated Models</i>								
LV-10	29.5	1,000	20.5	42.5	3.3	32.8	35	300
LV-10W	29.5	1,000	27.0	42.5	3.3	32.8	35	325
LV-100	29.5	2,200	20.5	42.5	3.3	32.8	66	350
LV-100W	29.5	2,200	27.0	42.5	3.3	32.8	60	375
<i>Manual Foot Pedal Pump Operated Models</i>								
LV-50E	29.5	1,000	20.5	42.5	3.3	32.8	10	340
LV-50WE	29.5	1,000	27.0	42.5	3.3	32.8	10	370
LV-100E	29.5	2,200	20.5	42.5	3.3	32.8	18	440
LV-100WE	29.5	2,200	27.0	42.5	3.3	32.8	18	460

DISTRIBUTED BY:



Bishamon Industries Corporation

5651 East Francis Street
Ontario, California 91761-3601

(909) 390-0055 • (800) 358-8833
Fax (909) 390-0060

www.bishamon.com