

# Handling Boxes

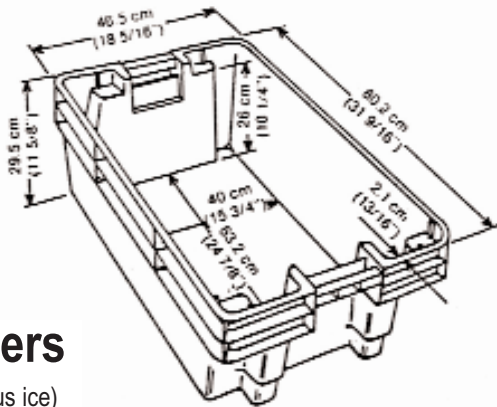
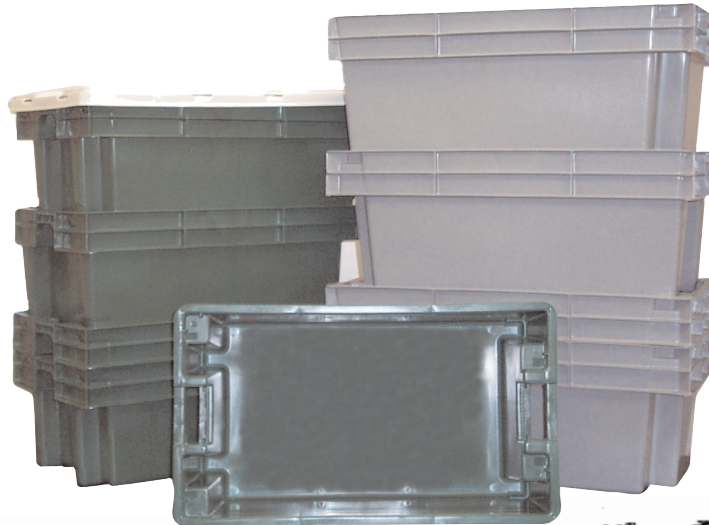

## 70 Liters

(100 lbs. plus ice)

OD 31 9/16" x 18 5/16" x 11 5/8" (LxWxH)  
 ID 24 7/8" x 15 3/4" x 10 1/4" (LxWxH)

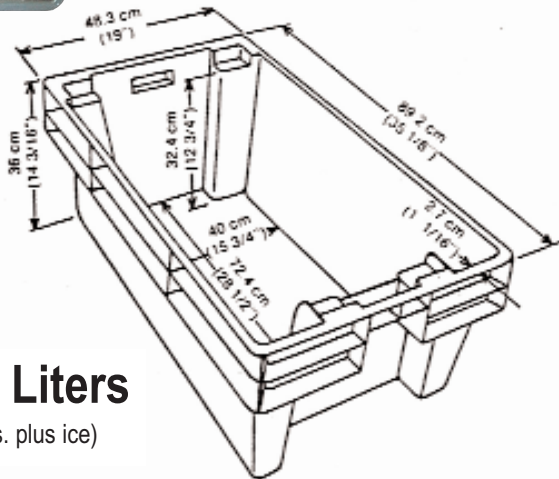

## 100 Liters

(140 lbs. plus ice)

OD 35 1/8" x 19" x 14 3/16" (LxWxH)  
 ID 28 1/2" x 15 3/4" x 12 3/4" (LxWxH)

### CONSTRUCTION

- Stiffness highly improved as opposed to conventional models, thanks to the sturdy built-in ribs, allowing stability and security during handling.
- Reinforced posts, especially designed to resist impact and wear.
- Strong and practical handles with lateral opening, which prevents dirt accumulation.
- Hard-wearing flat bottom.
- Meet FDA and HPB requirements and chemically inert.

### IMPRINTING

- Can be branded for identification purposes having customer logotype hot stamped or embossed.
- Imprinting protected by ribs and always made on the same side for fast and easy stacking.

### SPECIFICATIONS

- **Weight**  
 70 liters: 8.8 lbs. (4 kg)  
 100 liters: 11.2 lbs. (11.2 kg)
- **Nesting Height:** 8" (20.3 cm)  
 70% space-saving in storage and shipping when empty
- Can be stacked or nested with a simple 180° rotation
- Comes with or without draining holes

### COLOR

- Standard: 70L - Green  
 100L - Gray

**NOTE:** Lid available for 70 liter box only

0203