



**Up to 8 ft.  
mounting  
height**

# Powered Aire Model

# BCE

**Stainless Steel Construction !**

**1/2 HP direct drive motors**

**Mount on interior for Insect  
and Climate Control**

**Mount on exterior for  
Insect Control**



## PRODUCT DATA SINGLE SPEED UNITS

Model	BCT 1-36	BCT 1-42	BCT 1-48	BCT 1-60	BCT 2-60	BCT 2-72	BCT 2-84	BCT 2-96	BCT 3-108	BCT 3-120	BCT 3-132	BCT 4-144
Nozzle width inches	36	42	48	60	60	72	84	96	108	118	133	145
Max. FPM at Nozzle	3516	3516	3516	3516	3516	3516	3516	3516	3516	3516	3516	3516
Max. CFM at Nozzle	2418	2820	3223	3552	4250	4838	5640	6445	7254	8059	9088	9676
Avg. FPM at Nozzle	3416	2697	2359	2125	2822	3147	2697	2360	3139	2684	2343	3147
CFM at Nozzle	2170	2163	2155	2167	3245	4326	4314	4334	6489	6472	6475	8652
Outlet Velocity Uniformity	95%	93%	92%	91%	95%	95%	93%	92%	95%	94%	95%	95%
Number of Motors	1	1	1	1	2	2	2	2	3	3	3	4
Horse Power per motor	1/2	1/2	1/2	1/2	1/2	1/2	1/2	1/2	1/2	1/2	1/2	1/2
Weight (Lbs)	85	92	99	113	142	164	184	198	241	269	279	328

Sound Level: 60 dba / Sound level measured 10 ft. from the unit in a free field based on a one-motor unit.

Single Phase Motor Voltage Available:	120	208/230	480	575
Amp Draw Per Motor:	7.3	3.0	1.7	1.3

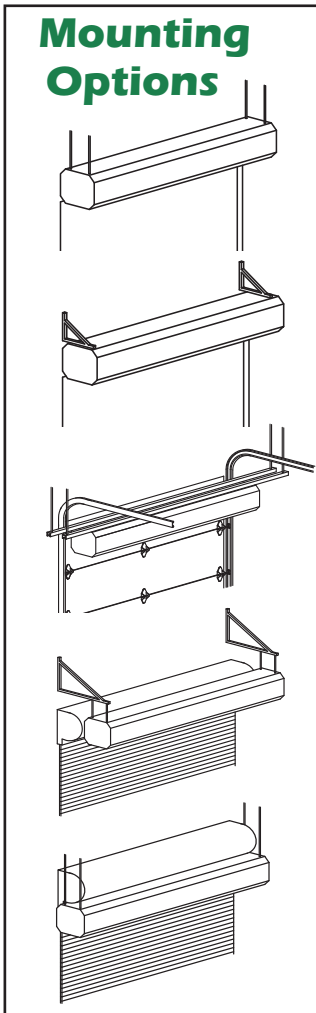

**For information contact: DACO Corp. at 800-345-3226**

# BCE

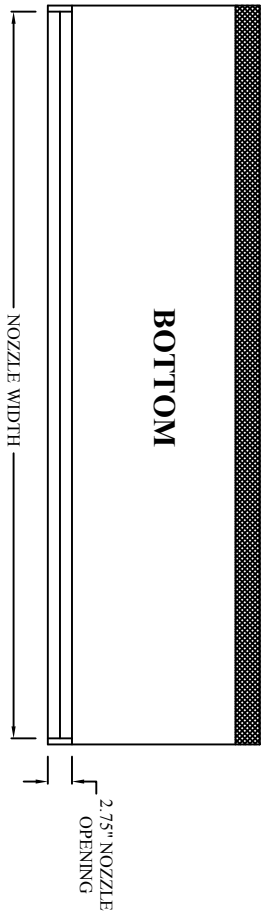
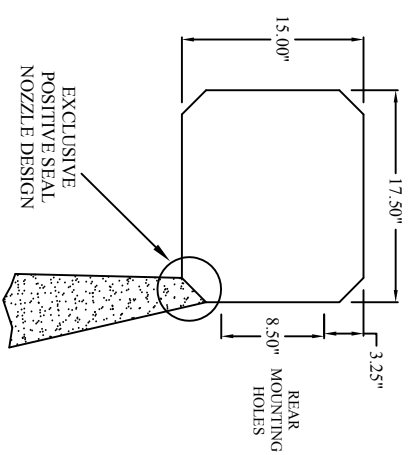
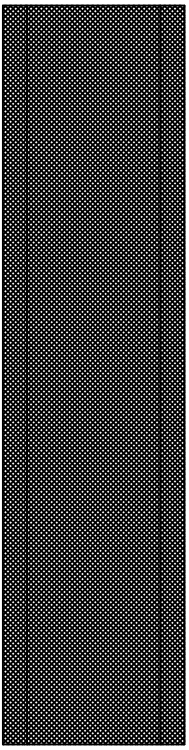
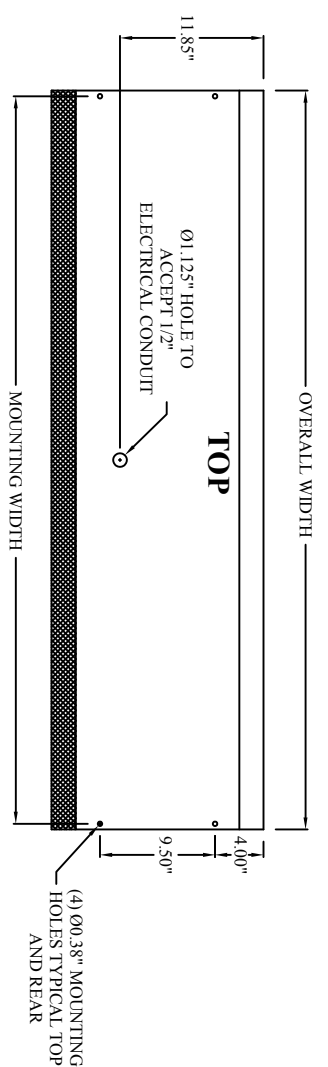

MODEL NUMBER	BCE 1-36	BCE 1-42	BCE 1-48	BCE 1-60	BCE 2-60	BCE 2-72	BCE 2-84	BCE 2-96	BCE 3-108	BCE 3-120	BCE 3-132	BCE 4-144
OVERALL WIDTH	37	43	49	61	61	73	85	97	109	119	134	146
NOZZLE WIDTH	36	42	48	60	60	72	84	96	108	118	133	145
MOUNTING WIDTH	36 1/16	42 1/16	48 1/16	60 1/16	60 1/16	72 1/16	84 1/16	96 1/16	108 1/16	118 1/16	133 1/16	145 1/16

**JOB NAME :** \_\_\_\_\_ **TAG(S) :** \_\_\_\_\_

**LOCATION :** \_\_\_\_\_ **MODEL # :** \_\_\_\_\_

**CONTRACTOR :** \_\_\_\_\_ **ENGINEER :** \_\_\_\_\_

**POWERED AIRE™ INC.**  
109 Mordensen Rd. Greenville, PA 16125

**DATE:** 03/01/11 **PART DESCRIPTION:** POWERED AIRE SYSTEMS  
**DRAWN BY:** B.K.L. **MODEL:** BCE BUG CONTROL UP  
**PART/FILE#:** BCE **TO EIGHT FEET HIGH**

