

HAND RAIL

SAFE. STRONG. PROVEN.



Cubic Hand Rail is easy to install and clearly defines pedestrian walkways, loading docks, production areas, assembly lines and more. Ideal for in-plant offices, work platforms, balconies, stairs, equipment crossovers, landings, catwalks and mezzanines.



- Double level or triple level handrail systems are offered. Custom designs also available.
- Square tubing is stronger and easier to clean than pipe fitting designs.
- Continuous top rail provides visually attractive, finished appearance.
- Hand Rails are professionally engineered to meet all building codes including uniform and point load requirements.
- Patented intermediate railing connection is easy to install and allows for quick expansion.
- Floor mounted rail system with 4" kickplate is available as one complete package when used on mezzanines or other elevated platforms.
- Choose from 14 standard colors. Custom colors and paint finishes available upon request. Please note: Custom colors and finishes may affect price and lead time.



GENERAL SPECIFICATIONS

SAFE. STRONG. PROVEN.

DECK MOUNTED HANDRAIL

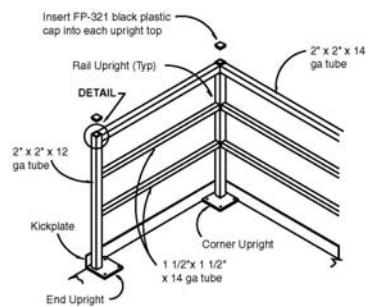

Always starting at a corner, position corner upright base plate flush with deck edge (tight against kickplate). Bolt (4) 3/8"o flatheads through deck, kickplate, and framing (as necessary) to mount upright. Drop rail horizontals (notch down) onto rail brackets, and position next upright using centerline dimensions on drawing. Fasten rails with (1) 5/16" bolt thru bracket into tinnerman nut on rail horizontal at each end.

When deck material is grating, set upright atop grating and place 2" x 2" grating plates along underside of grating if framing not present. Fasten down upright with (4) 3/8"o flatheads (1 or 2 through grating plates).

PLAN VIEW

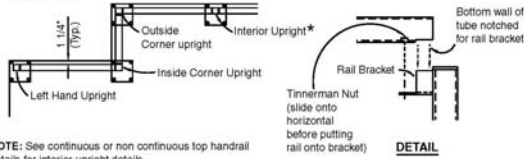

*NOTE: See continuous or non continuous top handrail details for interior upright details.

Hand Rail Options Available:

- Double Level
- Triple Level
- Seven Level
- Expanded Metal/Mesh
- Vertical



Patented Rail Connection

NON CONTINUOUS TOP HANDRAIL

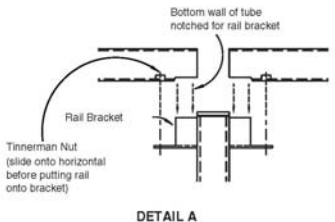
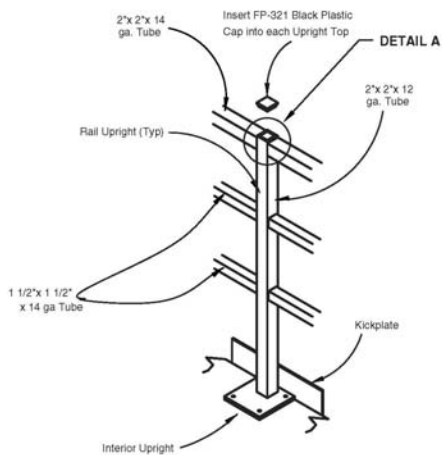

16770 West Victor Rd • New Berlin, WI 53151

262-789-1966 • 800-826-7061 • www.cubicdesigns.com