

SAFETY RAIL

SAFE. STRONG. PROVEN.



Independently tested and proven to withstand the impact of a 10,000 lb. forklift moving at 5 mph, Cubic Safety Rail protects your equipment and employees from costly accidents. Professionally engineered to provide maximum protection for people, machinery, building walls, shelving, conveyors, racks, finished product, raw material supplies, loading docks and more.



Results of impact test available upon request.

- Cubic Safety Rail design saves time and allows for quick removal of rail sections—no tools required. Easy to add rail sections or dismantle railing for relocation.
- Exclusive, patented Quik-Connect™ rail hanger.
- Single rail (17" high) or double rail (43" high) design. Heights can be mixed and matched to fit any application.
- Pre-punched columns simplify installation.
- Accommodates straight railing runs and runs with inside or outside corners.
- Columns are high tensile 5" x 5" x 3/16" steel tube with 3/4" x 10" x 10" welded baseplates.
- Lower rail is 2" clear to floor to provide backstop for pallet storage
- Safety Rail comes standard with yellow, durable powder coat finish. Custom colors and paint finishes available upon request. Please note: Custom colors and finishes may affect price and lead time.
- Cubic Safety Rail is available for purchase online at:

<http://www.cubicdesigns.com/spg>



GENERAL SPECIFICATIONS

SAFE. STRONG. PROVEN.

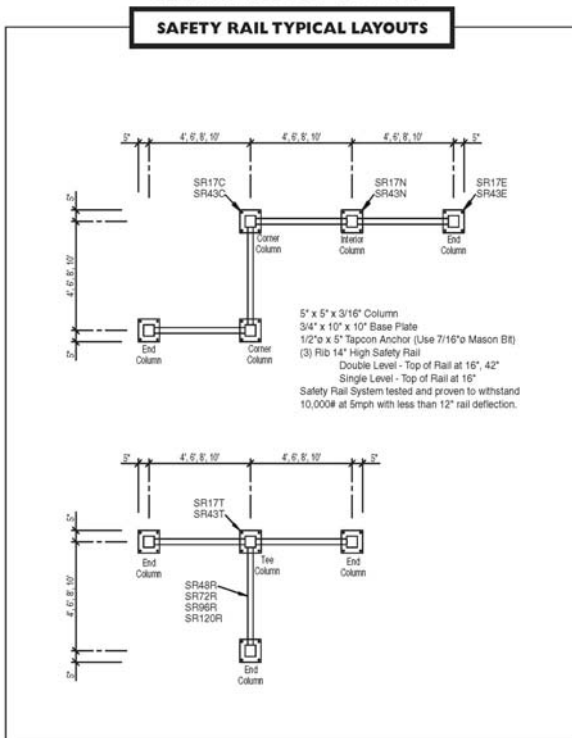
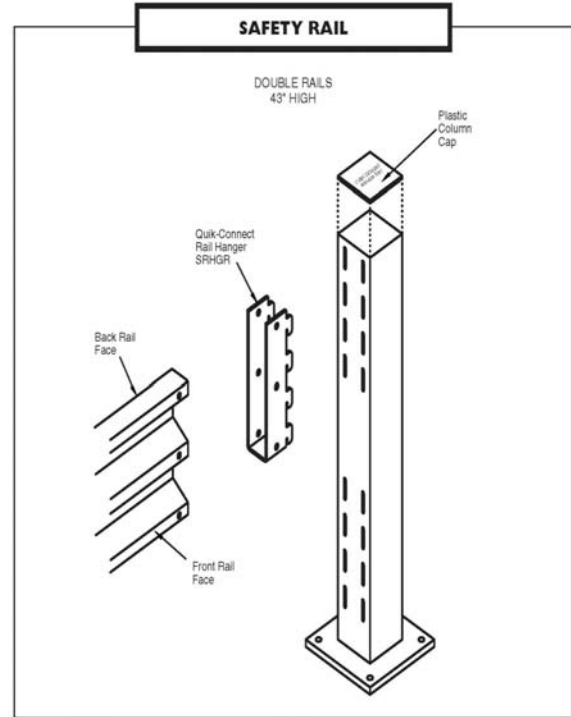
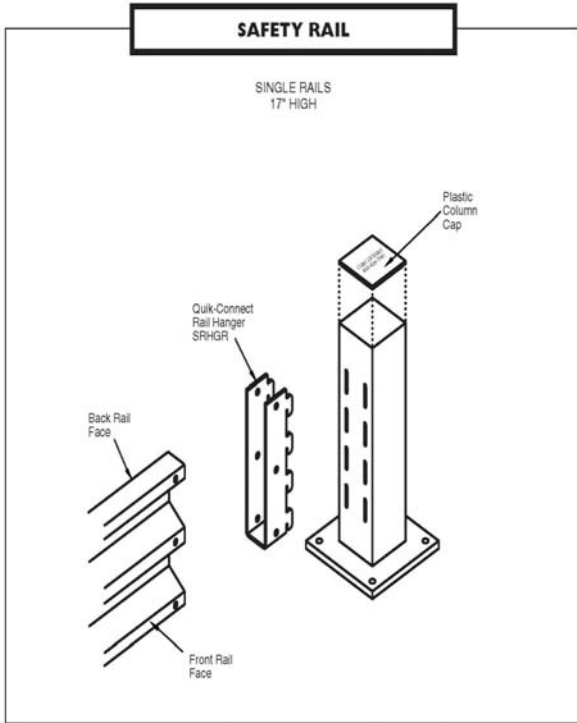

INCREASING YOUR PRODUCTIVITY

DACO

MATERIAL HANDLING & PACKAGING SOLUTIONS

www.DACOcorp.com
800-345-3226

SHIPS
48
STANDARD YELLOW
SHIPS IN 48 HOURS

16770 West Victor Rd • New Berlin, WI 53151

262-789-1966 • 800-826-7061 • www.cubicdesigns.com