

# 5 Gallon Round Container

**Letica**<sup>®</sup>  
CORPORATION  
The Power of Packaging

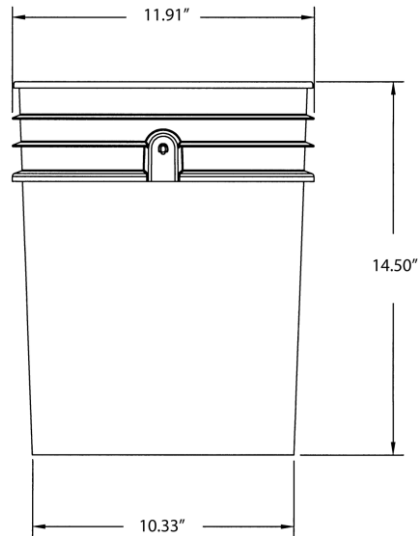

## Features

- Taller height reduces spillage during filling and capping
- Polished surface provides attractive appearance
- Reinforcing ribs maintain container shape
- Tapered design allows for container nesting
- Hot fill capability up to 190°F with appropriate materials and freezer compatible
- Heat transfer decoration and 6 color offset print capability
- Accepts plastic or metal handle

**PRODUCT CODE**.....5DM

**COMPATIBLE LIDS**.....5LTB, 5LHV, 5NLR & 5LTEO

## SPECIFICATIONS

Height.....14.50"  
 Outer Diameter.....11.91"  
 Thickness.....90 mil  
 Print Area.....31" x 8.25"  
 Resin.....HDPE

## VOLUME

Practical Fill.....5.10 gal. / 19.30 liters  
 Overflow.....5.40 gal. / 20.44 liters

## PACKAGING

Pack Count.....120  
 Pack Dimensions.....48.9" x 36.6" x 49.6"  
 Cubic Feet.....51.3  
 Packs per Pallet.....2

## ORDER QUANTITIES (53' Truckload)

5DM with compatible lids.....6,720 bases & lids

**DACO**

(877) 247-3834 - dacocorp.com



Coast to Coast  
Manufacturing Capabilities

The above information is general sales material only. LETICA MAKES NO WARRANTIES HEREIN, EXPRESS OR IMPLIED, INCLUDING THE WARRANTY OF MERCHANTABILITY OR FITNESS FOR A PARTICULAR USE OR PURPOSE. As Letica continues to improve its products and processes, Letica reserve the right to alter or modify any product and/or specification at any time without notice or obligation. Please contact your Letica sales representative to ensure you have the most recent product information.