

POWER PALLET 2000

A complete drive package that can be installed onto your manual jack, converting it into a very powerful, yet ultra-compact, motorized jack.

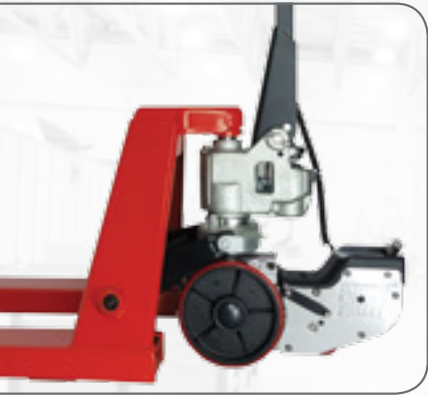

*"A REVOLUTION IN **ERGONOMIC** AND **COST EFFECTIVE** PALLET MOVING."*



BY
POWERHANDLING

SMARTER. SMALLER. STRONGER.

Back Of Truck & Delivery

Most trucking companies have manual jacks in the back of their trailers for maneuvering pallets. For this task the PPR-2000 is ideal, being ultra-compact and light yet very powerful. Switch into "Truck Mode" and the speed slows, torque increases and the unit will operate with the handle fully upright. Even the heaviest pallet loads can be easily maneuvered... regardless of the size or strength of the operator.

POWER PALLET 2000



ERGONOMIC



MANEUVERABLE



SPEED CONTROL



RETRO-FIT KIT



POWER PALLET 2000

TURNING RADIUS

With a turning radius the same as for a manual jack, there is nothing more compact or user friendly for maneuvering heavy loads in tight spaces.

'TRUCK MODE'

A push of the mode button changes the unit from "warehouse mode" (green light) to "truck mode" (orange light)... designed for back of truck operation. In this mode the unit can be operated with the handle vertical and max speed is reduced.

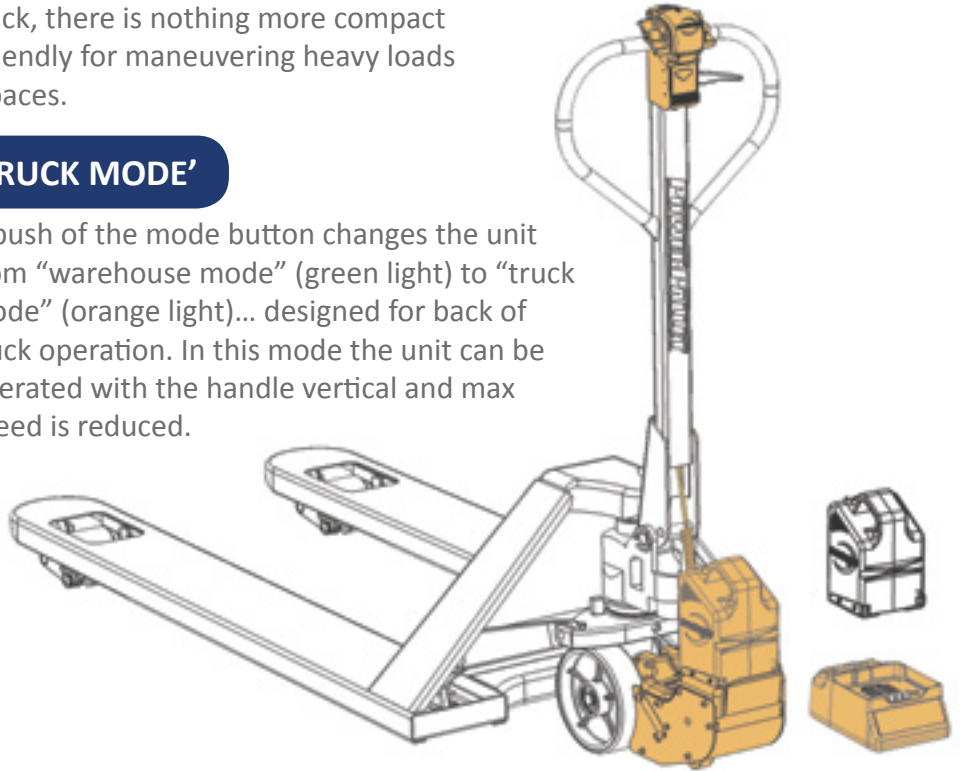

EFFORTLESS TURNING

The patented design of the PowerPallet 2000 locates the drive wheel within a spring loaded drive arm. A max of 350lbs is born by the drive wheel (*enough load transfer for reliable traction*), while all additional weight is born by the steering wheels of the jack. This results in less effort maneuvering at low speeds.



BACK OF TRUCK

WAREHOUSE & DOCKS

POWERHANDLING

DACO

(877) 247-3834 - dacocorp.com

QUICK-CHANGE BATTERIES



Quick Change
Battery

Quick Charge Base Included

Rated to 3,500 lbs.

USA: 02/21/2018