

UNI-20 (pallet jack mode)

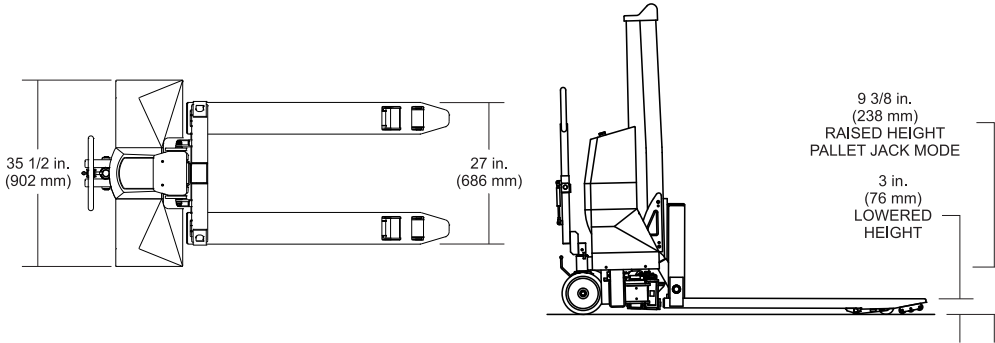

UNI-20 (high lift mode)

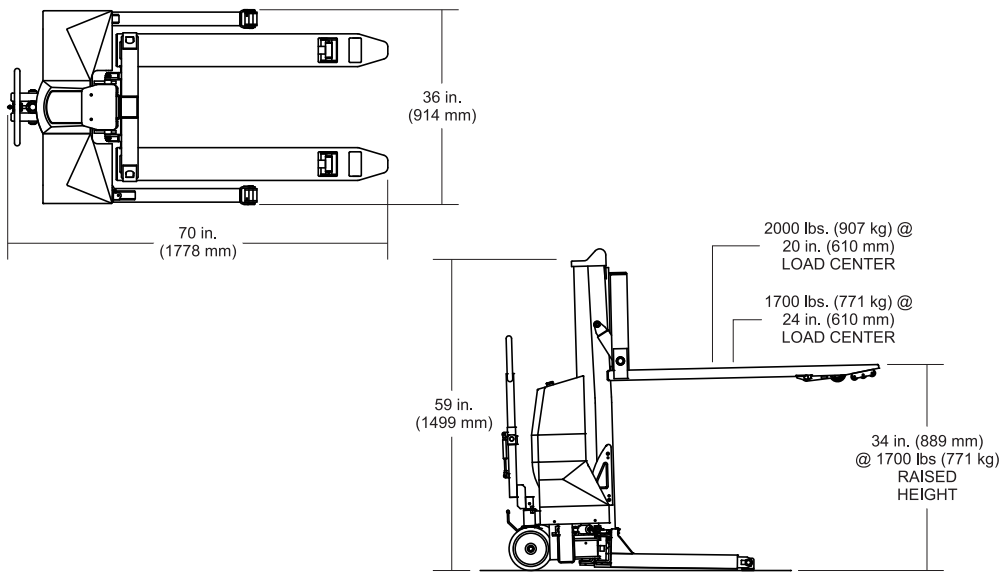

Standard Features:

- Can be used with standard GMA pallets, 48" x 40" CHEP pallets and/or skids
- Dual-purpose product allows for both transport and load positioning
- Handles and steers like a standard pallet jack
- Lifting fork height up to 36"
- Lift capacity up to 2000# (see chart)
- Multi-roller fork entry system for easy pallet entry and exit
- Foot operated brake on load wheels
- On-board, automatic battery charger
- Efficient 24 VDC battery system powers lift operation
- Electro-mechanical outrigger actuation with position sensors
- Electronic operator console with "Raise" and "Lower" push buttons, dual function key / battery disconnect switch, outrigger position LEDs, charger status LED and battery condition LED
- 8" diameter polyurethane steering wheels
- 3" diameter polyurethane load wheels
- Durable powder coated finish

Options:

- Outrigger Load Wheels
- Hand Controller
- Carriage Maintenance Kit

UniLift

Model	Pallet Jack Mode Capacity (lbs)	High Lift Mode Capacity 20" Load Center (lbs)	High Lift Mode Capacity 24" Load Center (lbs)	Approximate Shipping Weight (lbs)
UNI-20	2,000	2,000	1700	750

DISTRIBUTED BY:

DACO
(877) 247-3834 - dacocorp.com

Bishamon®