

# Introducing Bonar Plastics new line of Small Insulated Boxes

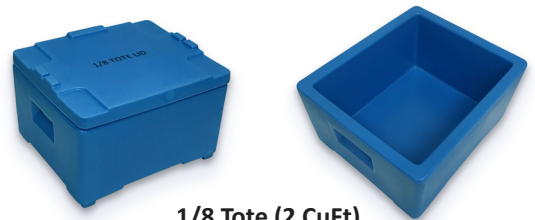

1/8 Tote (2 CuFt)



1/4 Tote (4 CuFt)



1/2 Tote (9 CuFt)



- (3) New sizes- 1/8 tote- 2 CuFt, 1/4 tote- 4 CuFt, 1/2 tote- 9 CuFt
- Manufactured with FDA/Health Canada compliant resins
- New integrated gasket in lid to reduce thermal loss
- Boxes stack together to maximize cube
- Integrated handles for ease of handling
- Boxes smooth, with radiused corners for ease of cleaning
- Boxes do not have drains, easily dumped by hand
- Boxes filled with 2 lb. PUR Foam (Polyurethane) / R-value 7 per inch

[www.bonarplastics.com](http://www.bonarplastics.com)

Made in the USA



**DACO**

(877) 247-3834 - dacocorp.com

**2 CuFt**  
1/8 Tote



**Weight:**

30 lbs.

**Internal Dimensions:**

L: 19.1"

W: 15.6"

H: 10.6"

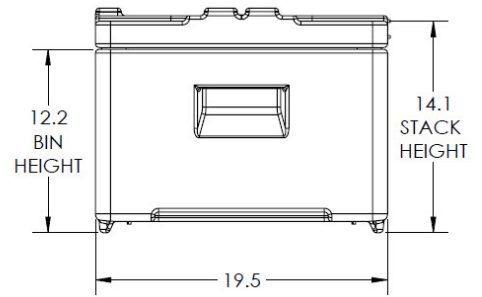
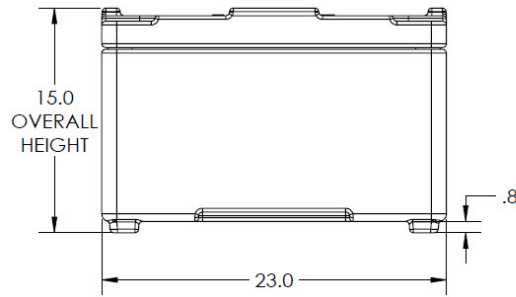

**4 CuFt**  
1/4 Tote



**Weight:**

41 lbs.

**Internal Dimensions:**

L: 18.0"

W: 14.5"

H: 22.1"

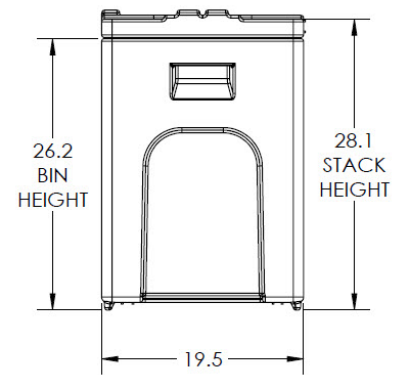
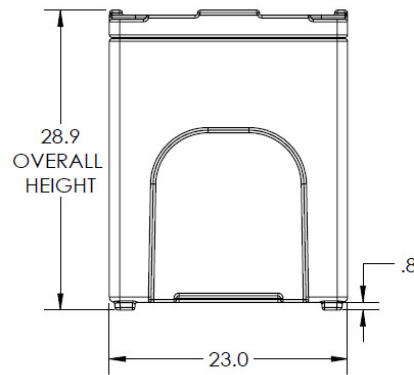

**9 CuFt**  
1/2 Tote



**Weight:**

79 lbs.

**Internal Dimensions:**

L: 33.7"

W: 19.2"

H: 22.1"

