



Admiral BENCH SCALES



**IP69K-RATED
HIGH-PRESSURE
HIGH-TEMPERATURE
WASHDOWNS**



The Admiral utilizes the model SSPW hermetically-sealed IP69K waterproof load cell.

FEATURING
190 STORM
WEIGHT INDICATOR

- Food Manufacturing
- Processing Facilities
- Chemical Industry

IP69K-RATED PROTECTION AGAINST THE HARSHNESS OF WASHDOWN ENVIRONMENTS

Cardinal Scale's Admiral bench scales feature an IP69K-rated load cell and indicator, so any sensitive electronics are fully protected against close-range high-pressure, high-temperature spray downs making them ideal for the food processing industry where equipment must be carefully sanitized. The heavy-duty stainless steel base is built solidly for high-usage durability.

The Admiral's colorful 190 STORM indicator is positioned at the optimum viewing height and out of the way of the product being weighed. The display tilt feature allows the display to be positioned just right for each operator. The entire LCD display can be set to any of seven different ColorZONE colors during checkweighing. This exclusive ColorZONE feature takes the guesswork out of the weighing process making the Admiral the top bench scale in the industry.



Cardinal Scale model CA8-15KGW-190 Admiral bench scale shown above. The Admiral is available in 15-kg and 60-kg metric capacities and 30-lb and 120-lb imperial capacities.

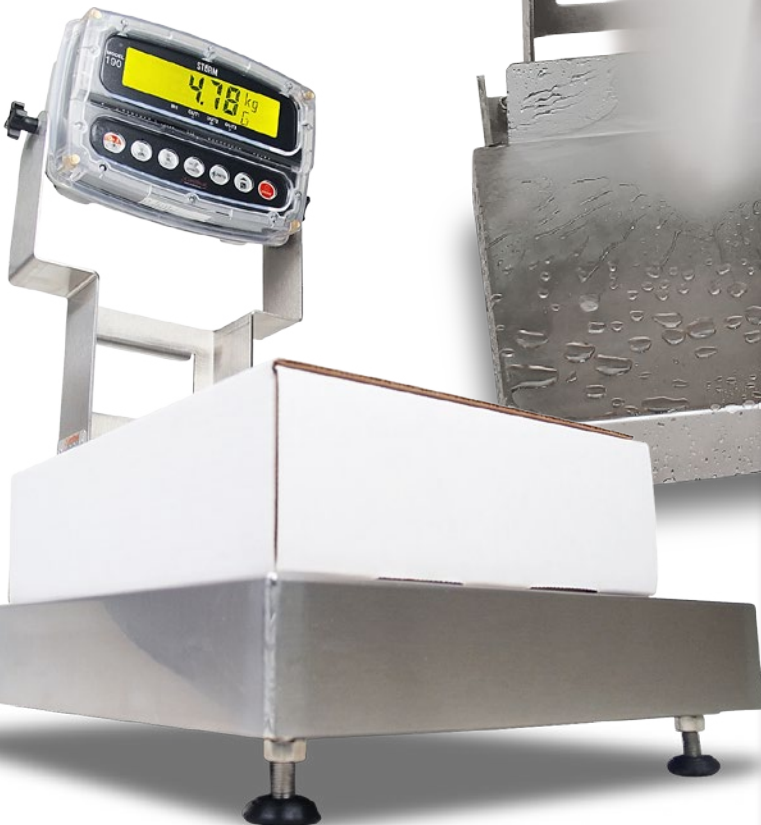

The Admiral's built-in carrying handle comes in "handy" when you need to lift and move the scale.



CAPACITIVE TOUCH

The Admiral's keypad senses the operator's finger from inside the enclosure, thus eliminating the need for any opening in the front of the IP69K-rated indicator. A red status LED for each key signals to the operator that their touch has been received. There are no moving parts to wear out or exposed electronics in the scale's indicator.

In environments that require heavy washdowns, such as in the food processing industry, the combination of water, chemicals, high pressure and high temperature can prove fatal for electronic circuits and instrumentation. The Admiral bench scale's IP69K rating offers complete assurance that the scale is both durable and resistant and conforms to the highest protection rating possible.

The Admiral's polycarbonate and ABS enclosure to the weight display is watertight and allows operation in the harshest of environments while the stainless base and column construction ensure long-lasting durability. The scale's 190 STORM indicator features four captive screws in the back panel, so they cannot be lost when unscrewed (important for food processing applications).



ColorZONE CHECKWEIGHING



The Admiral's vivid display changes color automatically as pre-assigned target weights are reached during checkweighing. You know immediately when you've hit the acceptable weight range with the exclusive ColorZONE feature.

INTERLOCKING COMMODITY TRAY



Lift-off stainless steel tray for easy cleaning. Fastens securely in place via two stainless steel locking tabs.



Admiral BENCH SCALES

Shipping Weight: 28 lb / 13 kg
Load Cell: Model SSPW-20KG stainless steel

MODEL	CAPACITY	INDICATOR
CA8-15KGW-190	15 kg x 0.001 kg	190 STORM
CA8-30W-190	30 lb x 0.002 lb	190 STORM

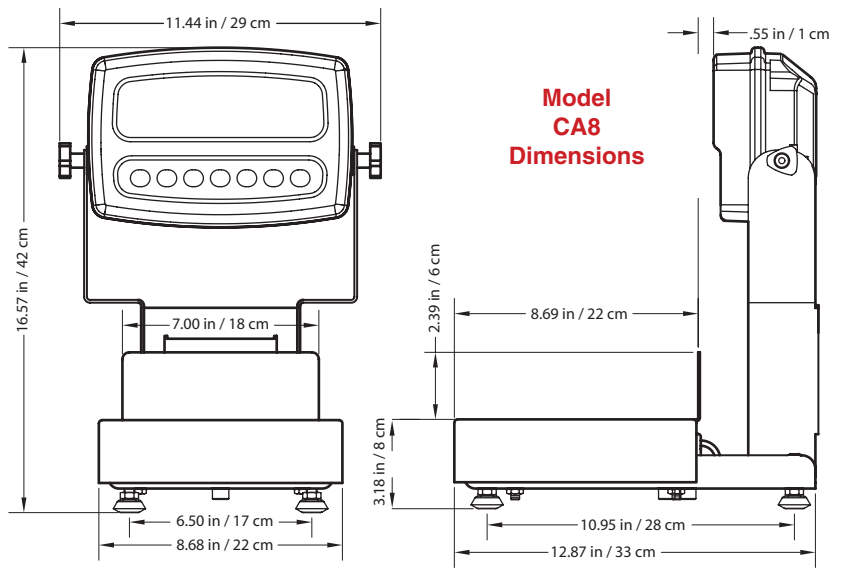

Admiral BENCH SCALES

Shipping Weight: 40 lb / 18 kg
Load Cell: Model SSPW-75KG stainless steel

MODEL	CAPACITY	INDICATOR
CA12-60KGW-190	60 kg x 0.02 kg	190 STORM
CA12-120W-190	120 lb x 0.05 lb	190 STORM

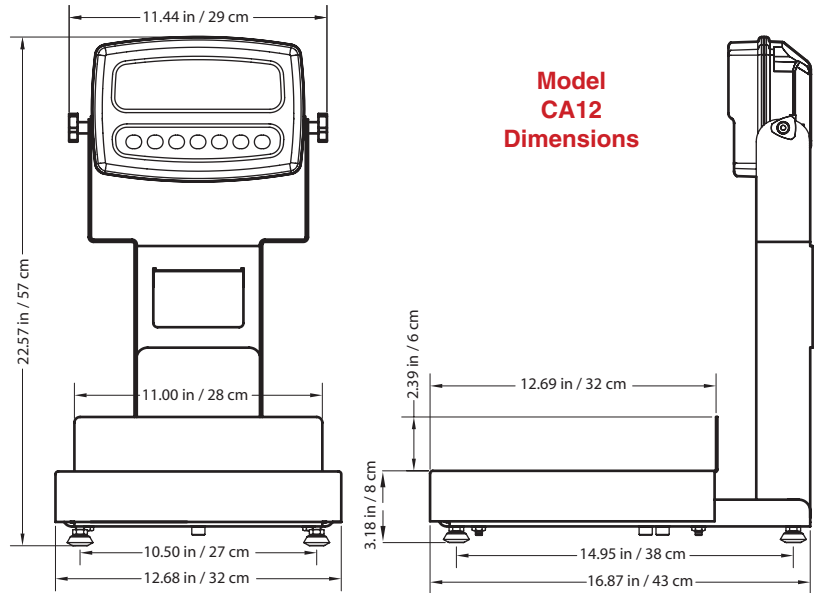

Model 190 Indicator
AC Power (shown left)
Comes standard

Both the 190 and 190DC may utilize an optional rechargeable Lithium Ion battery.

Model 190DC Indicator
DC Power (shown left)

Optional DC Power Supply

Power Requirements:	100 to 240 VAC (50/60 Hz) at 0.4A Max.
Enclosure Type:	Indicator: IP69K-rated polycarbonate and ABS Scale Base: Stainless steel IP69K-rated
Operating Temperature:	14 to 104 °F (-10 to +40 °C)
Display:	Six digit, seven segment, 1.0-inch/25-mm high backlit LCD
Transducer Excitation:	5.18 VDC
Signal Input Range:	0.5 mV min. to 40 mV max. (with dead load boost)
Tare Capacity:	Scale capacity
Sample Rate:	1 to 100 samples per second, selectable
Keypad:	Color coded capacitive touch type, 7 keys
Standard I/O:	(1) bi-directional RS232

Cardinal Scale reserves the right to improve, enhance or modify features and specifications without prior notice. All registered trademarks are the property of their respective owners.



(877) 247-3834 - dacocorp.com

JAR/00/0917/359B