



MAGNUM

Model 2300 SD-U Uniform Side Drive Case Sealer

The Magnum 2300 SD-U utilizes dual side belt drives that provide the best performance for uniform case sealing applications, including narrow or long boxes. The opposing side belts create optimum grip on the case and allow for upgrades such as flap folding options to improve productivity. A simple turn of the crank handles quickly adjust the machine for different box sizes.

Highlight's case sealers are equipped with Magnum 200 Series tape heads which provide accurate and consistent tape application to the top and bottom of cases using any 2" carton sealing tape. Magnum tape heads are engineered with the most heavy duty and reliable components in the industry, and are packed with features for flexibility.

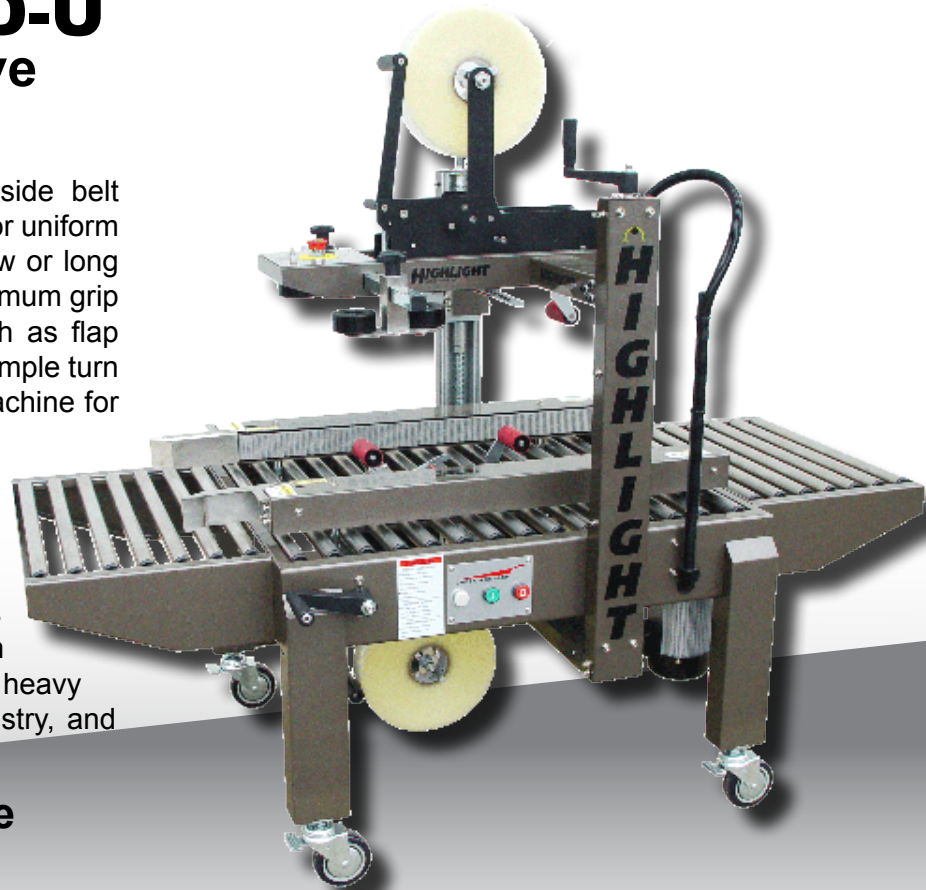

**For simple and reliable
case sealing!**



HIGHLIGHTS

- » Simple operation and high versatility make the Magnum 2300 SD-U the Highlight Industries workhorse case sealer
- » Magnum tape heads are engineered for performance and packed with features to provide the most reliable tape head in the industry
- » Designed to operate at up to 30 cases per minute for increased productivity

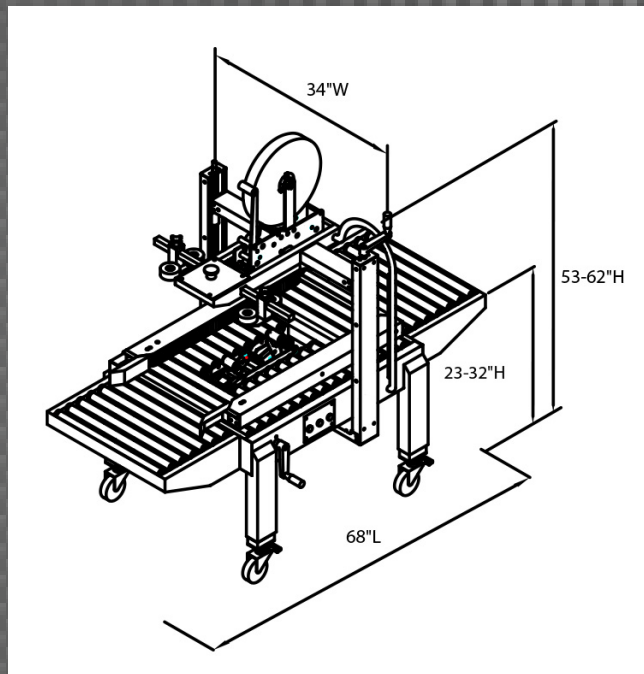

SIMPLE CONTROLS



- Start Button
- Stop Button
- Power Indicator Light
- Crank Handles and to adjust height and width
- Centrally Located Emergency Stop

SYSTEM SPECIFICATIONS

Classification	Side Drive Uniform	Machine Dimensions	70" L, 34" W, 55" H
Machine Operating Rate	Up to 30 Boxes per Minute	Case Size Capacity	4"-20" Wide, 5"-20" Tall, 5"-Unlimited Length *Optional 28"W x 28" H Capacity Available
Belt Speed	75 Feet per Minute	Roller Conveyor Length	16" Entry and Exit
Tape Heads	Highlight's Model 200 Series 2" Tape Heads Standard, 3" Optional	Machine Weight	375 Pounds
Working Height	Adjustable 23" to 32"	Electrical Requirements	120 V, 60Hz, 10 Amp



Roller Conveyors

The Magnum 2300 SD-U comes with 16 inch entry and exit conveyors with chromed steel rollers and smooth running precision bearings for easy case movement and long life.



Locking Swivel Casters

Highlight's heavy duty locking casters allow the Magnum 2300 SD-U to be easily moved around a facility to a work area, or moved aside when not in use.



Tape Head

The Magnum 2300 SD-U is equipped with a pair of Magnum 200 Series tape heads which are loaded with features to provide the most reliable and flexible tape heads in the industry.

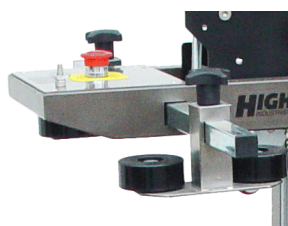

Top Guide Squeezer Rollers

The included squeezer rollers ensure the top flaps of the case are fully closed to provide a good sealing surface and keep the contents secure.

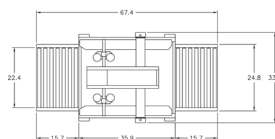

Heavy Duty

All-steel construction, sturdy design, and powder-coated surfaces make the Magnum 2300 SD-U durable and reliable for years of industrial use.

*Optional stainless steel construction available.