



MAGNUM

Model 4500 SD-R Random Side Belt Drive Case Sealer

The Magnum 4500 SD-R utilizes dual side belt drives that provide the best performance for random case sealing applications, especially for narrow or long cases. The machine automatically adjusts in height and width according to box size when in *random* mode, and can be set to *uniform* for faster operation.

Highlight's case sealers are equipped with Magnum 200 Series tape heads which provide accurate and consistent tape application to the top and bottom of cases using any 2" carton sealing tape. Magnum tape heads are engineered with the most heavy duty and reliable components in the industry, and are packed with features for flexibility.

**For reliable and
flexible operation!**



HIGHLIGHTS

- » Automatically adjusts to case dimensions for up to 15 cases per minute in *random* mode and up to 30 cases per minute in *uniform* mode
- » Magnum tape heads are engineered for performance and packed with features to provide the most reliable tape head in the industry
- » Heavy duty and intelligent design ensure long operating life and easy case movement

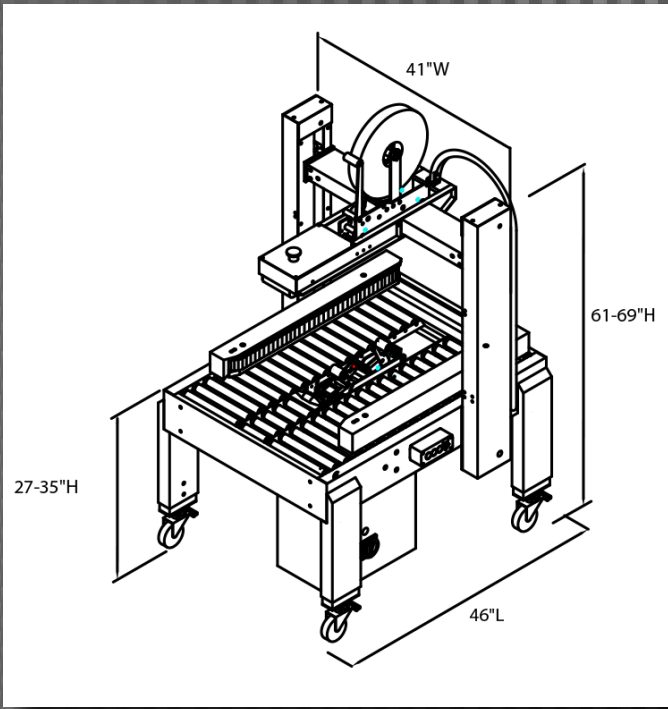

SIMPLE CONTROLS



- Start Button
- Stop Button
- Reset Button
- Power Indicator Light
- Mode Selector Switch
- 3 Taping Modes: Random, Fast Random, and Uniform
- Centrally Located Emergency Stop

SYSTEM SPECIFICATIONS

Classification	Side Belt Drive Random	Machine Dimensions	46" L, 41" W, 62" H
Machine Operating Rate	Up to 15 Boxes per Minute in <i>random</i> mode and up to 30 Boxes per Minute in <i>uniform</i>	Case Size Capacity	5" to 24" Wide, 5" to 24" Tall, 5" to Unlimited Length
Belt Speed	75 Feet per Minute	Machine Weight	650 Pounds
Tape Heads	Highlight's Model 200 Series 2" Tape Heads Standard, 3" Optional	Electrical Requirements	110 V, 60Hz, 10 Amp
Working Height	Adjustable 27" to 35"	Pneumatic Requirements	80 psi, 4 cfm



PLC Controls

The Magnum 4500 SD-R is controlled using a PLC for flexibility and multiple operating modes. This allows for added versatility and optional upgrades.



Locking Swivel Casters

Highlight's heavy duty locking casters allow the Magnum 4500 SD-R to be easily moved around a facility to a work area, or moved aside when not in use.



Tape Head

The Magnum 4500 SD-R is equipped with a pair of Magnum 200 Series tape heads which are loaded with features to give you the most reliable and flexible tape heads in the industry.

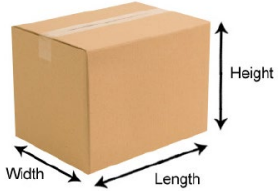

Automatic Adjust

The machine automatically adjusts to the dimensions of each case quickly to maximize productivity when sealing random sized boxes.

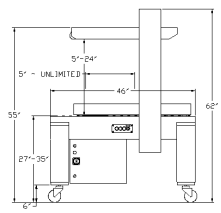

Heavy Duty

All-steel construction, sturdy design, and powder-coated surfaces make the Magnum 4500 SD-R durable and reliable for years of industrial use.

