



MAGNUM

Model 5850 SD-U FF

Automatic Uniform Side Drive Case Sealer

The Magnum 5850 SD-U FF is an adjustable side drive case sealer with flap folders designed to automatically fold the minor and major flaps of the boxes down and provide accurate and consistent tape application to uniform cases.

The Magnum 5850 SD-U FF will quickly and accurately fold and seal your cases and is built to stand up to years of use.

**For simple and reliable
case sealing!**



HIGHLIGHTS

- » Quick adjusting flap folding arms front flap plow, and rear automatic flap kicker easily folds all top case flaps
- » Magnum Tape heads are overbuilt for performance and packed with features to provide the most reliable tape head in the industry
- » Indexing stopper to prevent case jams and maximize output up to 26 cases per minute with no operator required

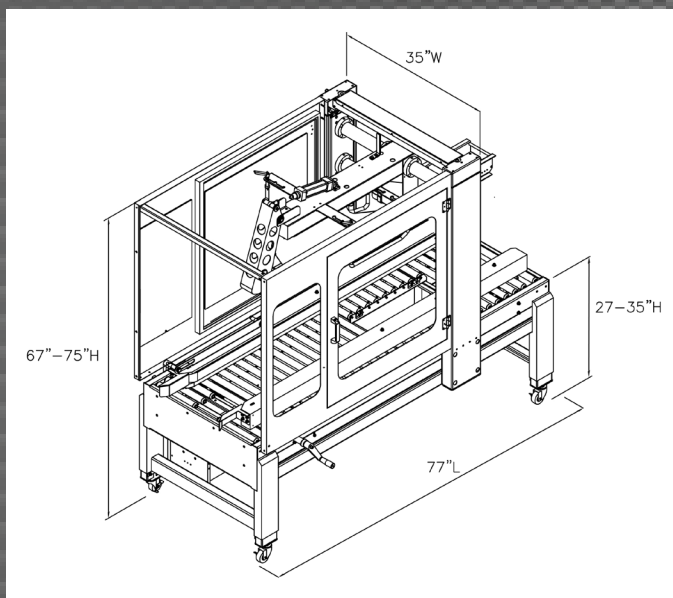

SIMPLE CONTROLS



- Start Button
- Stop Button
- Power Indicator Light
- Safety Doors
- Hand Crank to adjust side Belts and Height
- Centrally Located Emergency Stop

SYSTEM SPECIFICATIONS

Type	Side Belt Drive Uniform with Flap Folders	Machine Dimensions	77" L, 35" W, 67" H Standard
Machine Operating Rate	Up to 26 boxes per minute	Case Size Capacity	5" to 24" L, 5" to 20" W, 5"-20" H
Case Belt Speed	75 feet per minute	Pneumatic	80 psi, 2 cfm
Tape Head	Magnum 200 Series 2" Tape Heads Standard, 3" Optional	Machine Weight	750 Pounds
Working Height	Adjustable 27" to 35"	Electrical	120 V, 60Hz, 10 Amp

Automatic Flap Folders



The Magnum 5850 SD-U FF comes standard with adjustable flap folding arms, front flap plow, and rear flap kicker that automatically fold the top major and minor flaps of uniform cases. The automatic design makes for increased productivity with no operator required.

Locking Swivel Casters



Heavy duty locking casters allow the Magnum 5850 SD-U FF to be easily moved around a facility to a work area, or moved aside when not in use.

Tape Head



The Magnum 5850 SD-U FF is equipped with a pair of Magnum 200 series tape heads and are loaded with features to give you the most reliable and affordable tape heads in the industry.

Heavy Duty

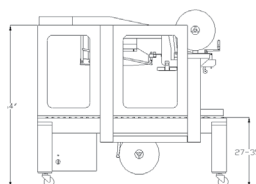

All-steel construction, sturdy design, and powder-coated surfaces make the Magnum 5850 SD-U FF durable and reliable for years of industrial use.



(877) 247-3834 - dacocorp.com

